

# Year 1

# Year 2

# Year 3

# Year 4

Fall

Spring

Fall

Spring

Fall

Spring

Fall

Spring

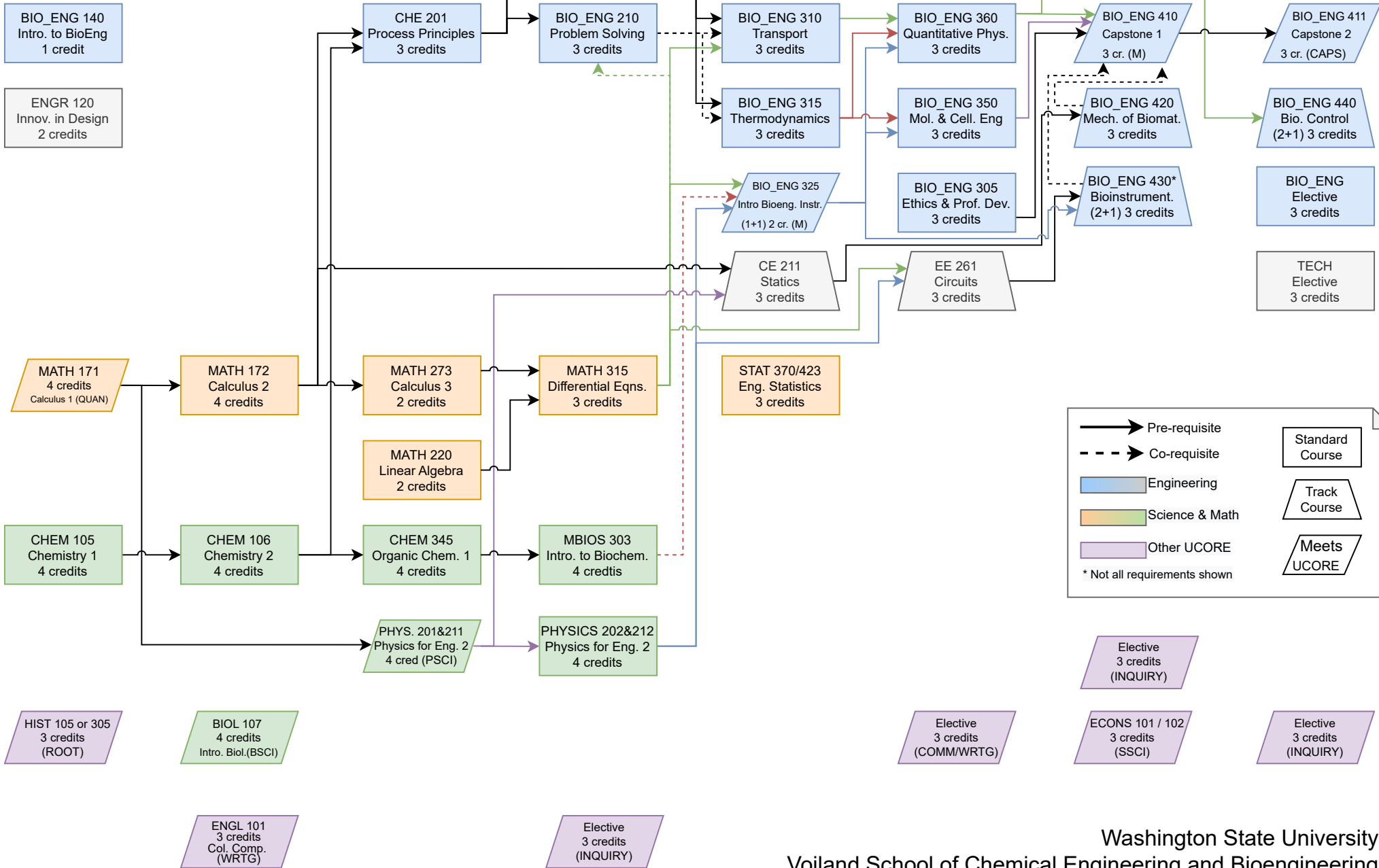

# At Previous Institution

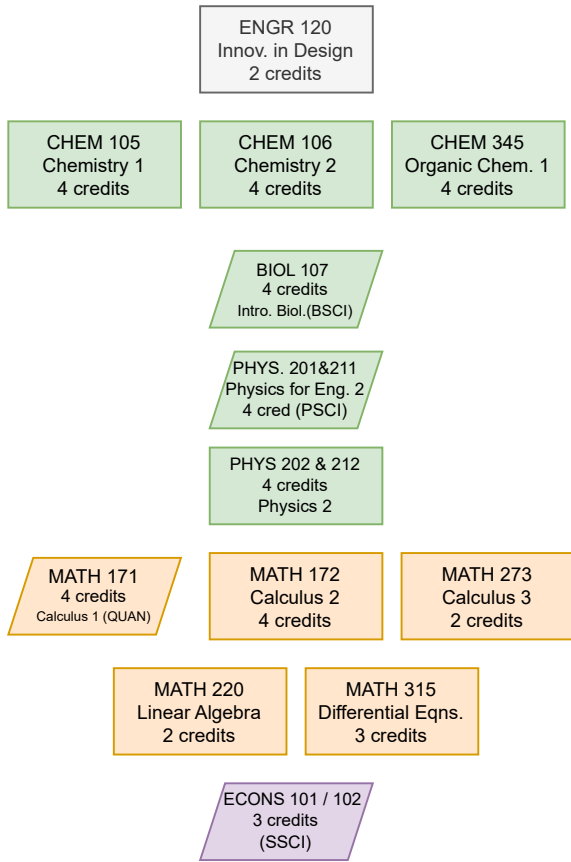

# Year 3

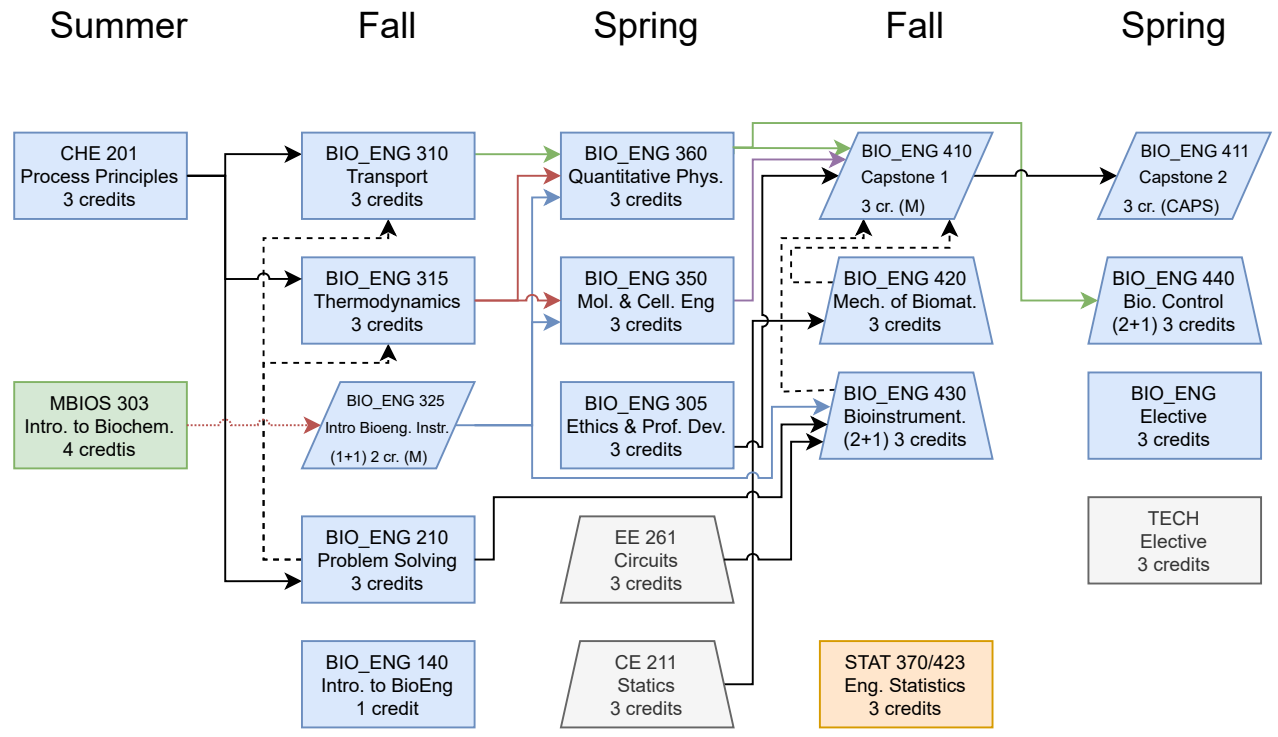

# Year 4

- Not required for those who completed a direct transfer agreement (DTA) associate degree
- May be required for those who completed an associate of science transfer (AS-T) degree
- See [WSU Admissions](#) and talk to your advisor

Elective 3 credits (UCORE)

Elective 3 credits (UCORE)

Elective 3 credits (UCORE)

Elective 3 credits (UCORE)

Elective 3 credits (UCORE)

Elective 3 credits (UCORE)

Washington State University  
 Voiland School of Chemical Engineering and Bioengineering  
 Bachelor of Science - Bioengineering  
**Biomedical Systems Option**  
**2-Year Program**  
 Fall 2023

