

Year 1

Year 2

Year 3

Year 4

Fall

Spring

Fall

Spring

Fall

Spring

Fall

Spring

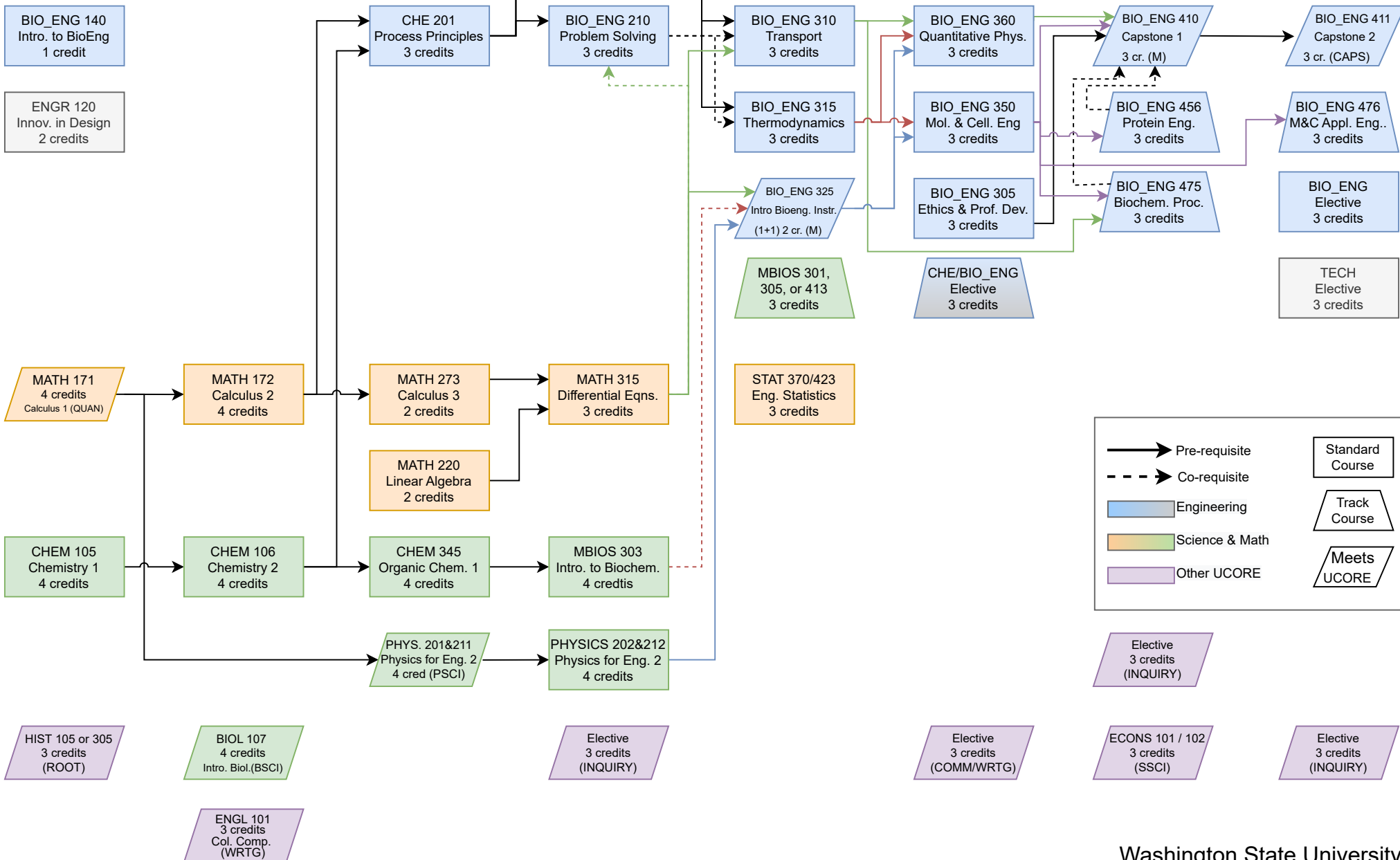

At Previous Institution

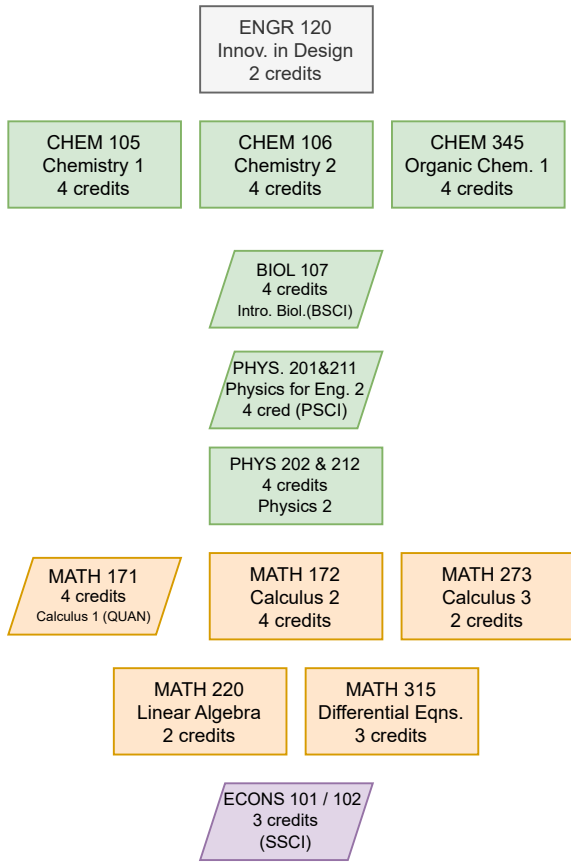

Year 3

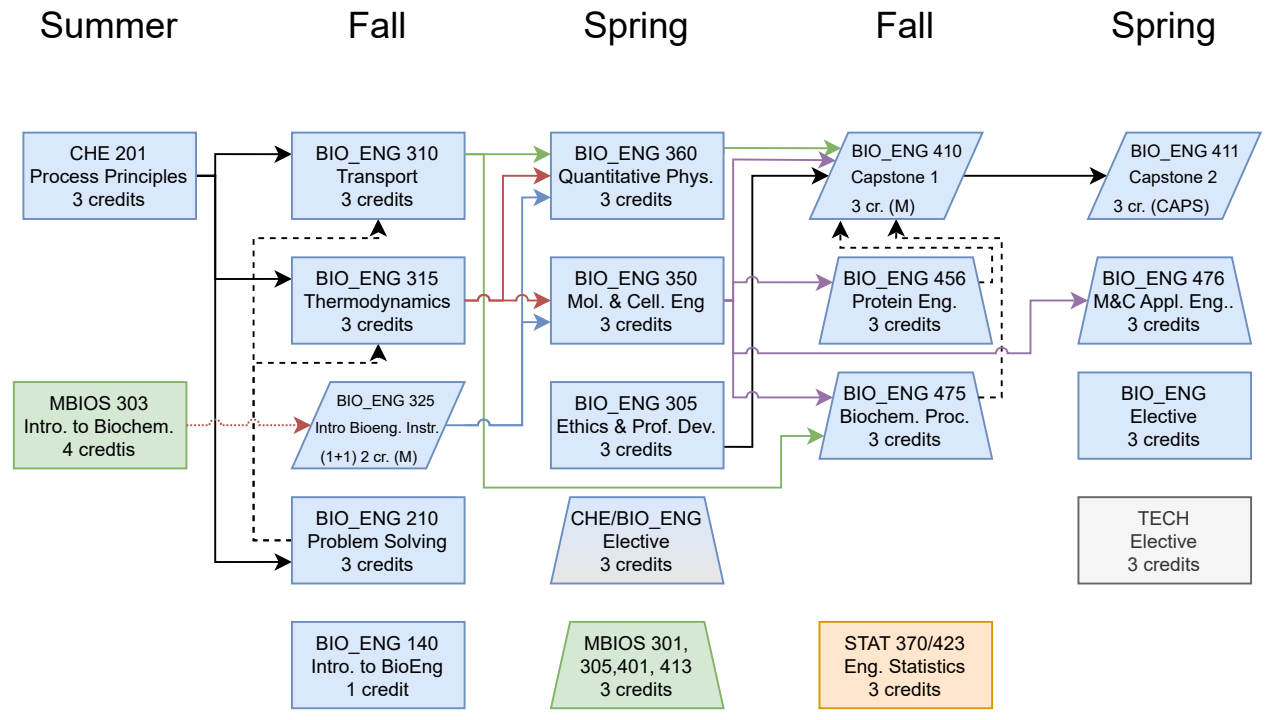

Year 4

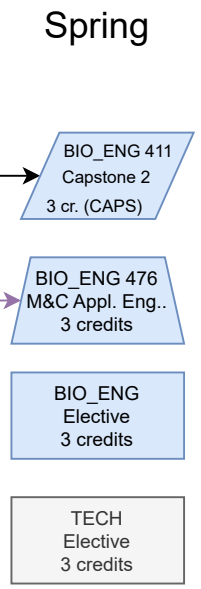

- Not required for those who completed a direct transfer agreement (DTA) associate degree
- May be required for those who completed an associate of science transfer (AS-T) degree
- See [WSU Admissions](#) and talk to your advisor



Washington State University
 Voiland School of Chemical Engineering and Bioengineering
 Bachelor of Science - Bioengineering
 Cellular and Molecular Option
 2-Year Program
 Fall 2023

